



Excelência e compromisso há mais de 20 anos.



Em 20/02/1999 começamos nossa história como compromisso em oferecer os melhores produtos e serviços para nossos clientes. Nossa sede fixada em Presidente Olegário-MG é a base para a produção e desenvolvimento contínuo.



Trabalhamos para oferecer as melhores soluções, atendendo as necessidades do mercado e construindo uma relação de confiança e prosperidade.



Atendendo nossos clientes de maneira personalizada, temos representação dos nossos produtos em todo território nacional, o que possibilita o acesso dos clientes aos produtos com máximo conforto e comodidade.

SUSTENTAÇÃO

Roldana de ferro

MEDIDAS	CARGA RECOMENDADA 01 ROLAMENTO	CARGA RECOMENDADA 02 ROLAMENTO
1 ½"	50	80
2"	75	120
2 ½"	100	160
3"	225	360
3 ½"	250	400
4"	275	440
5"	300	480
6"	350	560

Roldana de Nylon

MEDIDAS	CARGA RECOMENDADA 01 ROLAMENTO
2"	50
2 ½"	75
3"	100
4"	150

ROLDANA COM PINO AÇO 1020

Roldana em V com pino

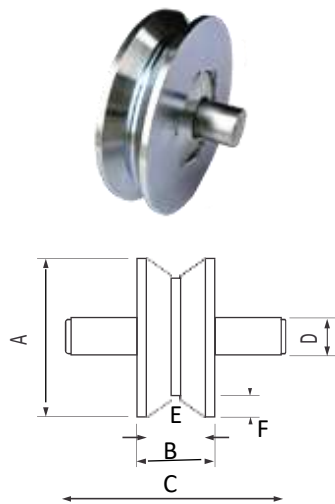

Para cantoneira 01 rol.

Código	Tamanho	A	B	C	D	E	F
1	1 ½"	37	13	35	8	17	6
5	2"	48	17	50	12	12	7
13	2 ½"	61	18	50	15	13	7
21	3"	74	18	50	15	13	7
29	3 ½"	86	18	50	17	13	7
39	4"	100	18	50	17	13	7
55	5"	125	23	50	30	17	7
63	6"	150	23	50	30	17	

Para cantoneira 02 rol.

Código	Tamanho	A	B	C	D	E	F
71	2"	48	24	50	12	6	5
77	2 ½"	61	24	50	15	12	9
85	3"	74	24	50	17	17	9
95	3 ½"	86	24	50	17	17	9
105	4"	100	24	50	17	17	9
125	5"	125	24	50	30	17	9
135	6"	150	24	50	30	17	

Roldana para elevação ou cabo de aço com pino

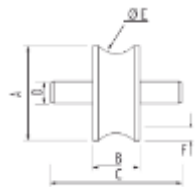

Para elevação ou cabo de aço com pino

Código	Tamanho	A	B	C	D	E	F
145	2"	48	15	50	12	10	5
147	2 ½"	61	15	50	15	10	5
295	3"	74	15	50	15	10	5
149	3 ½"	86	15	50	15	10	5
151	4"	100	15	50	15	10	5
155	5"	125	15	50	17	10	5
157	6"	150	15	50	17	10	5

Roldana para ferro redondo 5/8 e 3/4

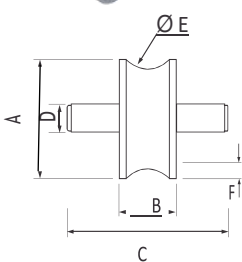

Para ferro redondo 5/8
01 rolamento

Código	Tamanho	A	B	C	D	E	F
3	1 ½"	37	18	50	8	15,8	4
7	2"	48	17	50	12	15,8	5
15	2 ½"	61	18	50	15	15,8	5
23	3"	74	18	50	15	15,8	5
31	3 ½"	86	18	50	17	15,8	5
41	4"	100	18	50	17	15,8	5
57	5"	125	23	50	30	15,8	6
65	6"	150	23	50	30	15,8	6

Para ferro redondo 5/8
02 rolamentos

Código	Tamanho	A	B	C	D	E	F
73	2"	48	24	50	12	15,8	5
79	2 ½"	61	24	50	15	15,8	5
87	3"	74	24	50	17	15,8	5
1173	3 ½"	86	24	50	17	15,8	5
107	4"	100	24	50	17	15,8	5
127	5"	125	30	50	30	15,8	5
137	6"	150	30	50	30	15,8	6

Para ferro redondo ¾ 01 rolamento

Código	Tamanho	A	B	C	D	E	F
9	2"	48	23	50	12	19,5	7
17	2 ½"	61	23	50	15	19,5	7
25	3"	74	23	50	15	19,5	7
33	3 ½"	86	23	50	17	19,5	7
43	4"	100	23	50	17	19,5	7
59	5"	125	24	50	30	19,5	7
67	6"	150	24	50	30	19,5	7

Para ferro redondo ¾ 02 rolamentos

Código	Tamanho	A	B	C	D	E	F
75	2"	48	24	50	12	19,5	7
81	2 ½"	61	24	50	15	19,5	7
89	3"	74	24	50	17	19,5	7
97	3 ½"	86	24	50	17	19,5	7
109	4"	100	24	50	17	19,5	7
129	5"	125	30	50	30	19,5	7
139	6"	150	30	50	30	19,5	7

Roldana para tubo ½ e ¾

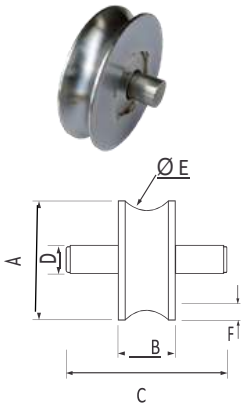

Para tubo ½ 01 rolamento

Código	Tamanho	A	B	C	D	E	F
1417	1 ½"	37	22	50	8	16	4
1360	2"	48	24	50	12	19,5	7
1380	2 ½"	61	24	50	15	19,5	7
1405	3"	74	24	50	15	19,5	7
1437	3 ½"	86	24	50	17	19,5	7
1435	4"	100	24	50	17	19,5	7
1441	5"	125	30	50	30	19,5	7
1442	6"	150	30	50	30	19,5	7

Para tubo ½ 02 rolamentos

Código	Tamanho	A	B	C	D	E	F
1364	2"	48	24	50	12	21,3	7
1379	2 ½"	61	24	50	15	21,3	7
1406	3"	74	24	50	15	21,3	7
1421	3 ½"	86	24	50	17	21,3	7
1413	4"	100	24	50	17	21,3	7
1426	5"	125	30	60	30	21,3	7
1428	6"	150	30	60	30	21,3	7

Para tubo ¾ 01 rolamento

Código	Tamanho	A	B	C	D	E	F
1375	1 ½"	37	24	50	10	22	4
1376	2"	48	30	50	12	26,7	8
1377	2 ½"	61	30	50	15	26,7	8
1378	3"	74	30	50	15	26,7	8
1415	3 ½"	86	30	50	17	26,7	8
1409	4"	100	30	50	17	26,7	8
1414	5"	125	30	30	30	26,7	8
1481	6"	150	30	60	30	26,7	8

Para tubo ¾ 02 rolamentos

Código	Tamanho	A	B	C	D	E	F
1395	2"	49	30	50	10	26,7	6
1355	2 ½"	60	30	50	10	26,7	8
1374	3"	74	30	50	10	26,7	8
1422	3 ½"	86	30	50	10	26,7	8
1369	4"	99	30	50	10	26,7	8
1412	5"	125	30	60	15	26,7	8
1419	6"	150	30	60	15	26,7	8

ROLDANA COM BUCHA

Roldana em V com bucha aço 1020

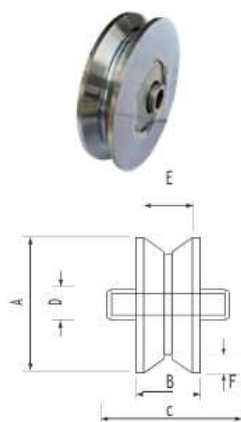

Para cantoneira 01 rol.

Código	Tamanho	A	B	C	D	E	F
2	1 ½"	37	13	22	10	7	3
6	2"	48	17	26	12	12	6
14	2 ½"	61	18	26	15	13	7
22	3"	74	18	26	15	13	7
30	3 ½"	86	18	26	17	13	7
40	4"	100	18	26	17	13	7
56	5"	125	23	30	30	17	7
64	6"	150	23	30	30	17	7

Para cantoneira 02 rol.

Código	Tamanho	A	B	C	D	E	F
72	2"	48	24	40	12	12	5
78	2 ½"	61	24	40	15	17	9
909	3"	74	24	40	17	17	9
96	3 ½"	86	24	40	17	17	9
106	4"	100	24	40	17	17	9
126	5"	125	24	40	30	17	
136	6"	150	24	40	30	17	

Roldana em V Nylon com bucha

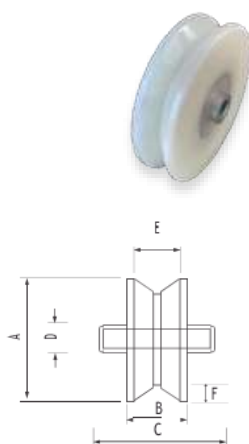

Para cantoneira Nylon

Código	Tamanho	A	B	C	D	E	F
160	1 ½"	37	13	22	10	7	3
640	2"	50	18	26	12	12	6
288	2 ½"	64	18	26	15	13	7
308	3"	75	18	26	15	13	7
487	3 ½"	86	18	26	17	13	7
309	4"	100	18	26	17	13	7

Roldana para ferro redondo 1/2, 5/8, 3/4 com bucha

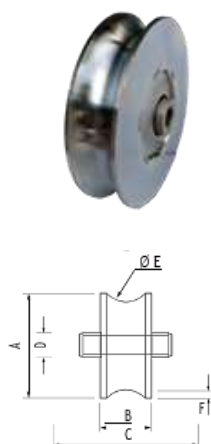

Para ferro redondo 5/8
01 rolamento

Código	Tamanho	A	B	C	D	E	F
4	1 ½"	37	18	50	8	15,8	
8	2"	48	17	50	12	15,80	5
16	2 ½"	61	18	50	15	15,80	
24	3"	74	18	50	15	15,80	5
32	3 ½"	86	18	50	17	15,80	5
42	4"	100	18	50	17	15,80	5
58	5"	125	23	50	30	15,80	6
66	6"	150	23	50	30	15,80	6

Para ferro redondo 5/8
02 rolamentos

Código	Tamanho	A	B	C	D	E	F
74	2"	56	24	40	12	15,8	5
80	2 ½"	61	24	40	15	15,8	5
88	3"	74	24	40	17	15,8	5
98	3 ½"	86	24	40	17	15,8	5
108	4"	100	24	40	17	15,8	5
128	5"	125	30	45	30	15,8	5
138	6"	150	30	45	30	15,8	5

Para ferro redondo 1/2 01 rolamento

Código	Tamanho	A	B	C	D	E	/F
1452	1 1/2"	37	21	50	10	16	4
1357	2"	48	23	50	12	19,5	7
1383	2 1/2"	61	23	50	15	19,5	7
1403	3"	74	23	50	15	19,5	7
1411	3 1/2"	86	23	50	17	19,5	7
1462	4"	100	23	50	17	19,5	7

Para ferro redondo 1/2 02 rolamentos

Código	Tamanho	A	B	C	D	E	/F
1455	1 1/2"	37	21	50	10	16	4
1359	2"	48	23	50	12	19,5	7
1382	2 1/2"	61	23	50	15	19,5	7
1458	3"	74	23	50	15	19,5	7
1410	3 1/2"	86	23	50	17	19,5	7
1425	4"	100	23	50	17	19,5	7

Para ferro redondo 3/4 01 rolamento

Código	Tamanho	A	B	C	D	E	F
10	2"	48	23	50	12	19,5	7
18	2 1/2"	61	23	50	15	19,5	7
26	3"	74	23	50	15	19,5	7
34	3 1/2"	86	23	50	17	19,5	7
44	4"	100	23	50	17	19,5	7
550	5"	125	24	50	30	19,5	7
68	6"	150	24	50	30	19,5	7

Para ferro redondo 3/4 02 rolamentos

Código	Tamanho	A	B	C	D	E	F
76	2"	48	24	40	12	19,5	7
82	2 1/2"	61	24	40	15	19,5	7
324	3"	74	24	40	15	19,5	7
99	3 1/2"	86	24	40	17	19,5	7
110	4"	100	24	40	17	19,5	7
130	5"	125	30	45	30	19,5	7
140	6"	150	30	55	30	19,5	7

Roldana para ferro redondo Nylon 5/8 , 3/4 com bucha



Para ferro redondo 5/8 01 rolamento

Código	Tamanho	A	B	C	D	E	F
985	1 1/2"	37	18	50	8	15,8	
164	2"	48	17	50	12	15,80	5
287	2 1/2"	61	18	50	15	15,80	
172	3"	74	18	50	15	15,80	5
662	3 1/2"	86	18	50	17	15,80	5
311	4"	100	18	50	17	15,80	5

Para ferro redondo 3/4 01 rolamento

Código	Tamanho	A	B	C	D	E	F
165	2"	48	23	50	12	19,5	7
173	3"	74	23	50	15	19,5	7
960	3 1/2"	86	23	50	17	19,5	7
177	4"	100	23	50	17	19,5	7

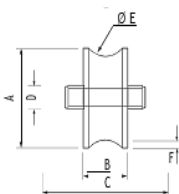

Roldana para tubo 1/2 e 3/4 com bucha

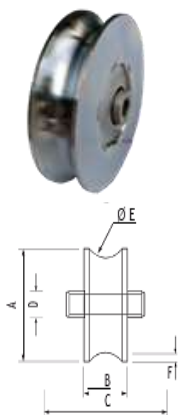

Para tubo 1/2 01 rolamento

Código	Tamanho	A	B	C	D	E	F
1461	1 1/2"	37	22	30	10	18	4
1357	2"	48	24	40	12	21,3	7
1383	2 1/2"	61	24	40	15	21,3	7
1403	3"	74	24	40	15	21,3	7
1411	3 1/2"	86	24	40	17	21,3	7
1462	4"	100	24	40	17	21,3	7
1444	5"	125	30	45	30	21,3	7
1463	6"	150	30	45	30	21,3	7

Para tubo 1/2 02 rolamentos

Código	Tamanho	A	B	C	D	E	F
1359	2"	48	24	40	12	19,5	7
1382	2 1/2"	61	24	40	15	19,5	7
1410	3"	74	24	40	17	19,5	7
1423	3 1/2"	86	24	40	17	19,5	7
1425	4"	100	24	40	17	19,5	7
1427	5"	125	30	45	30	19,5	7
1429	6"	150	30	45	30	19,5	7

Para tubo 3/4 01 rolamento

Código	Tamanho	A	B	C	D	E	F
1464	1 1/2"	37	28	40	10	22	4
1465	2"	48	30	40	12	26,7	6
1387	2 1/2"	61	30	40	15	26,7	8
1392	3"	74	30	40	15	26,7	8
1415	3 1/2"	86	30	40	17	26,7	8
1416	4"	100	30	40	17	26,7	8
1466	5"	125	30	45	30	26,7	8
1467	6"	150	30	45	30	26,7	8

Para tubo 3/4 02 rolamento

Código	Tamanho	A	B	C	D	E	F
1353	2"	49	30	40	12	26,7	6
1358	2 1/2"	60	30	40	15,5	26,7	8
1385	3"	74	30	40	17	26,7	8
1422	3 1/2"	86	30	40	17	26,7	8
1420	4"	99	30	40	17	26,7	8
1363	5"	125	30	50	20	26,7	8
1389	6"	150	30	50	20	26,7	8

Roldana para elevação ou cabo de aço com bucha

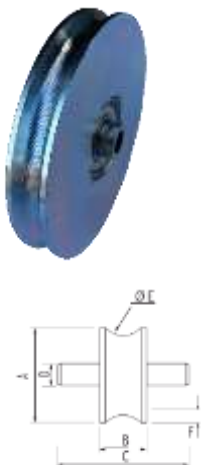

Para elevação ou cabo de aço com bucha

Código	Tamanho	A	B	C	D	E	F
146	2"	48	15	26	12	10	5
148	2 1/2"	61	15	26	15	10	5
325	3"	74	15	26	15	10	5
150	3 1/2"	86	15	26	15	10	5
152	4"	100	15	26	15	10	5
156	5"	125	15	26	17	10	5
158	6"	150	15	26	17	10	5

ROLDANA COM SUPORTE ABERTO

Roldana em V com suporte aberto

Em V suporte aberto parafuso



Codigo	Tamanho	A	B	C	D	E	F	G
619	1 ½	106	21	22	13	17	3	12,5
12	2" (fina)	122	24	22	13	15	6	12,5
491	2"	122	24	26	17	12	6	12,5
490	2 ½"	138	39	29	18	13	7	12,5
757	3"	138	39	29	18	13	7	12,5

Em V suporte aberto rebitada

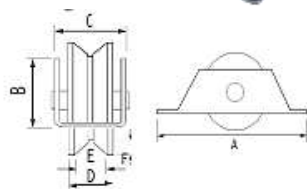

Codigo	Tamanho	A	B	C	D	E	F	G
342	1 ½	106	21	22	13	7	7	3
932	2" (fina)	138	24	26	15	12	12	6
179	2"	138	24	26	17	12	12	6
323	2 ½"	138	39	29	18	13	13	7
741	3"	138	39	29	18	13	13	7

Roldana em U com suporte aberto

Em U suporte aberto parafuso



Codigo	Tamanho	A	B	C	D	E	F	G
806	1 ½	106	21	22	13	3/8	4	12,5
616	2"	122	24	26	18	15,8	5	12,5
777	2 ½"	138	39	29	18	15,8	5	12,5
778	3"	138	39	29	18	15,8	5	12,5

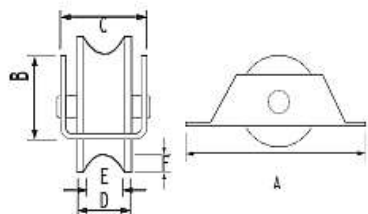

Em U suporte aberto rebitada

Codigo	Tamanho	A	B	C	D	E	F
893	1 ½	106	21	22	13	3/4	4
620	2"	122	24	26	18	15,8	5
425	2 ½"	138	39	29	18	15,8	5
627	3"	138	39	29	18	15,8	5

Roldana em V com suporte aberto Nylon



Em V suporte aberto parafuso Nylon

Codigo	Tamanho	A	B	C	D	E	F	G
738	1 ½	106	21	22	13	7	3	12,5
982	2"	122	24	26	18	12	6	12,5
1079	2 ½"	138	39	29	18	13	7	12,5
406	3"	138	39	29	18	13	7	12,5

Em V suporte aberto rebitada Nylon

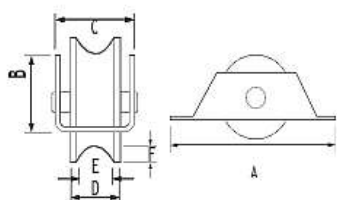

Codigo	Tamanho	A	B	C	D	E	F
937	1 ½	106	21	22	13	7	3
828	2"	122	24	26	18	12	6
829	2 ½"	138	39	29	18	13	7
830	3"	138	39	29	18	13	7

ROLDANA COM SUPORTE FECHADO

Roldana em V com suporte fechado



Em V suporte fechado parafuso

Codigo	Tamanho	A	B	C	D	E	F	G
722	1 ½	39	36	25	13	7	3	12,5
731	2"	58	47	30	17	12	6	12,5
750	2 ½"	68	55	30	18	13	7	12,5
751	3"	87	65	30	18	13	7	12,5
868	3 ½"	107	80	30	18	13	7	12,5
754	4"	107	80	30	18	13	7	12,5

Em V suporte fechado rebitado

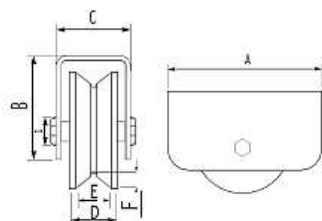

Codigo	Tamanho	A	B	C	D	E	F
386	1 ½"	39	36	25	13	7	3
181	2"	58	47	30	17	12	6
317	2 ½"	68	55	30	18	13	7
318	3"	87	65	30	18	13	7
362	3 ½"	107	80	30	18	13	7
319	4"	107	80	30	18	13	7

Roldana em U com suporte fechado



Em U suporte fechado parafuso

Codigo	Tamanho	A	B	C	D	E	F	G
779	1 ½"	39	36	25	13	3/8	4	12,5
773	2"	58	47	30	18	15,8	5	12,5
774	2 ½"	68	55	30	18	15,8	5	12,5
775	3"	87	65	30	18	15,8	5	12,5
994	3 ½"	107	80	30	18	15,8	5	12,5
776	4"	106	80	30	18	15,8	5	12,5

Em U suporte fechado rebitado

Codigo	Tamanho	A	B	C	D	E	F
623	1 ½"	39	36	25	13	3/8	4
182	2"	58	47	30	18	15,8	5
717	2 ½"	68	55	30	18	15,8	5
186	3"	87	65	30	18	15,8	5
1244	3 ½"	107	80	30	18	15,8	5
188	4"	106	80	30	18	15,8	5

Roldana em V com suporte fechado Nylon



Em V suporte fechado rebitado Nylon

Codigo	Tamanho	A	B	C	D	E	F	G
1037	1 ½"	39	36	25	13	7	3	12,5
548	2"	58	47	30	17	12	6	12,5
405	2 ½"	68	55	30	18	13	7	12,5
171	3"	87	65	30	18	13	7	12,5
908	3 ½"	107	80	30	18	13	7	12,5
713	4"	107	80	30	18	13	7	12,5

Em V suporte fechado parafuso Nylon

Codigo	Tamanho	A	B	C	D	E	F
983	1 ½"	39	36	25	13	7	3
789	2"	58	47	30	17	12	6
790	2 ½"	68	55	30	18	13	7
918	3"	87	65	30	18	13	7
654	3 ½"	107	80	30	18	13	7
953	4"	107	80	30	18	13	7

Roldana em U com suporte fechado Nylon

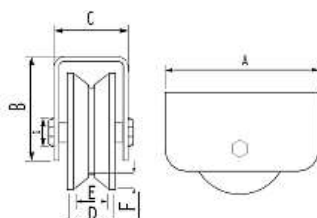

Em U suporte fechado Parafuso Nylon

Codigo	Tamanho	A	B	C	D	E	F	G
1468	1 ½"	39	36	25	13	7	4	12,5
766	2 "	58	47	30	18	15,8	5	12,5
600	2 ½ "	68	55	30	18	15,8	5	12,5
573	3"	87	65	30	18	15,8	5	12,5
	3 ½ "	107	80	30	18	15,8	5	12,5
1012	4"	107	80	30	18	15,8	5	12,5

Em U suporte fechado rebitado Nylon

Codigo	Tamanho	A	B	C	D	E	F
1469	1 ½"	39	36	25	13	7	4
936	2 "	58	47	30	18	15,8	5
377	2 ½ "	68	55	30	18	15,8	5
539	3"	87	65	30	18	15,8	5
1470	3 ½ "	107	80	30	18	15,8	5
322	4"	107	80	30	18	15,8	5

Roldana trucada em aço 1020

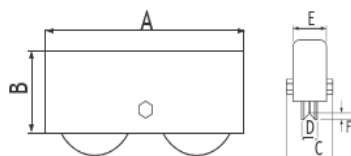

Trucada em V

Codigo	Tamanho	A	B	C	D	E	F
951	2 ½ "	170	54	69	21	50	6
952	3"	200	65	69	21	50	7
959	4"	250	80	69	21	50	7

Trucada em U

Codigo	Tamanho	A	B	C	D	E	F
970	2 ½ "	170	54	69	21	50	6
948	3"	200	65	69	21	50	7
929	4"	250	80	69	21	50	7

Trucada em U3/4

Codigo	Tamanho	A	B	C	D	E	F
869	2 ½ "	170	54	69	23	50	7
971	3"	200	65	69	23	50	7
949	4"	250	80	69	23	50	7

Roldana com base giratória em V aço 1020

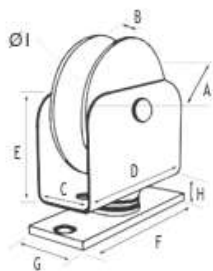

Base giratória V

Codigo	Tamanho	A	B	C	D	E	F	G	H	I
1004	2"	48	17	26	59	48	83	30	10	6
1005	2 1/2"	61	18	26	8	56	83	30	10	7
1006	3"	74	18	26	87	67	83	30	10	7

Roldana com base giratória em U aço 1020

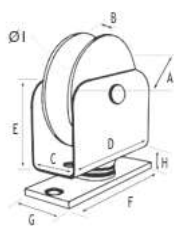

Base giratória U5/8

Codigo	Tamanho	A	B	C	D	E	F	G	H	I
966	2"	48	18	26	59	48	83	30	10	15,8
967	2 1/2"	61	18	26	8	56	83	30	10	15,8
976	3"	74	18	26	87	67	83	30	10	15,8

Base giratória U3/4

Codigo	Tamanho	A	B	C	D	E	F	G	H	I
275	2"	48	23	26	59	48	83	30	10	19,5
20	2 1/2"	61	23	26	8	56	83	30	10	19,5
511	3"	74	23	26	87	67	83	30	10	19,5

Roldana em U3/4 aço 1020 com engraxadeira

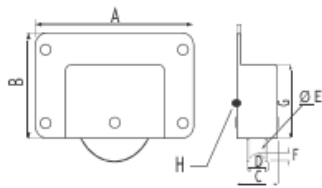

Metalon 30mm

Codigo	Tamanho	A	B	C	D	E	F	G	H
547	2 1/2"	120	54	30	21	19,05	5	50	1/4
368	3"	135	90	30	21	19,05	5	65	1/4

Metalon 40mm

Codigo	Tamanho	A	B	C	D	E	F	G	H
507	2 1/2"	120	54	40	21	19,05	5	50	1/4
772	3"	135	90	40	21	19,05	5	65	1/4

Metalon 50mm

Codigo	Tamanho	A	B	C	D	E	F	G	H
503	2 1/2"	120	54	50	21	19,05	5	50	1/4
833	3"	135	90	50	21	19,05	5	65	1/4

Roldana em V aço 1020 com engraxadeira

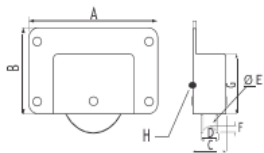

Metalon 30mm

Codigo	Tamanho	A	B	C	D	E	F	G	H
509	2 1/2"	120	54	50	21	18	5	50	1/4
879	3"	135	90	50	21	18	5	65	1/4

Metalon 40mm

Codigo	Tamanho	A	B	C	D	E	F	G	H
1475	2 1/2"	120	54	50	21	18	5	50	1/4
1477	3"	135	90	50	21	18	5	65	1/4

Metalon 50mm

Codigo	Tamanho	A	B	C	D	E	F	G	H
1476	2 1/2"	120	54	50	21	18	5	50	1/4
1478	3"	135	90	50	21	18	5	65	1/4

DIVERSOS

Pino com rolamento

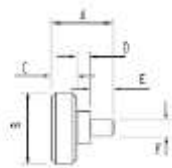

Pino com rolamento

Codigo	Referencia	A	B	C	D	E	F	G
200	Pino com Rol. 608	8	4	4	8	16	22	7
201	Pino com Rol. 6201	8	6	7	12	21	32	10
294	Pino com Rol. 6202	10	7,5	7	15	23	35	11
202	Pino com Rol. 6203	8	7,5	7	17	26	40	12
204	Pino com Rol. 6204	20	9	10		30	48	14
350	Pino com Rol. 6303	10	12,5	7		33	62	16
1334	Pino com Rol. 6308	40	19	9		42	90	23

Pino com rolamento e chapa

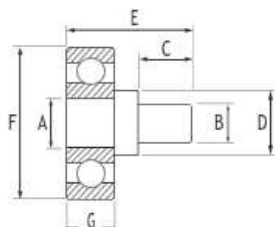

Pino com rolamento

Codigo	Referencia	A	B	C	D	E	F	G	CHAPA
407	Pino com Rol. 6201	8	6	7	12	21	32	10	
1101	Pino com Rol. 6202	10	7,5	7	15	23	35	11	1" 1/4 x 3/16 x 80
919	Pino com Rol. 6203	8	7,5	7	17	26	40	12	1" 1/4 x 3/16 x 80
1051	Pino com Rol. 6204	20	9	10		30	48	14	1" 1/4 x 3/16 x 80
852	Pino com Rol. 6206	10	30	7		33	62	16	1" 1/4 x 3/16 x 100
203	Pino com Rol. 6308	40	19	9		42	90	23	1" 1/4 x 3/16 x 140

Pino guia



Pino guia aço

Codigo	Referencia	A	B	
206	12x50 capa 43mm	43	14	12
964	12x65 capa 43mm	43	14	12
765	12x50 capa 48mm	48	15	12
1471	12x65 capa 48mm	48	15	12
207	15x50 capa 43mm	43	14	12
818	17x50 capa 66mm	66	20	17

Pino guia Nylon

Codigo	Referencia	A	B	
1100	12x50 capa 43mm	43	18	12
1013	12x65 capa 43mm	43	18	12
681	12x50 capa 48mm	48	18	12
1472	12x65 capa 48mm	48	18	12
944	15x50 capa 43mm	43	14	12
563	17x50 capa 66mm	66	20	17
1239	5/8x100 s/ rosca c/ capa 48mm Nylon injetado	48	20	



Pino guia rosqueado

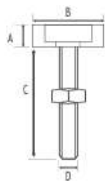

Pino guía rosqueado ferro

Codigo	Referencia	A	B	C	D
962	1/2x50 capa 43mm	14	43	50	1/2
726	1/2x50 capa 48mm	14	48	50	1/2
633	1/2x85 capa 43mm	14	43	85	1/2
1494	1/2x85 capa 48mm	14	48	85	1/2

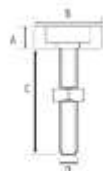

Pino guía rosqueado nylon

Codigo	Tamanho	A	B	C	D
304	1/2x50 capa 43mm	14	43	50	1/2
352	1/2x50 capa 48mm	14	48	50	1/2
1091	1/2x85 capa 43mm	14	43	85	1/2
1129	1/2x85 capa 48mm	14	48	85	1/2
1330	PIRULITO	19	23	57	1/2



Rodizio torneado

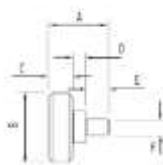

Rodizio torneado

Codigo	Tamanho	A	B	C	D	E	F
214	1"	18	25,4	8	4	6	6
215	1 1/4"	18	31,6	7	4	6	6
216	1 1/2"	18	38,2	8	4	6	6
221	1" Nylon injetado	16	26	9	4	5	4

Orelhinha



Orelhinha

Codigo	Descrição	A	B	C
904	Orelhinha 3/16	5,3	33	22,2
896	Orelhinha 5/16	8,2	33	22,2
900	Orelhinha 3/8	10,7	33	22,2

Ferrolho

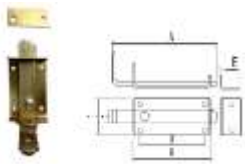

Ferrolho

Codigo	Tamanho	A	B	C	D	E	F
856	Ferrolho n° 2	100	55	49	31	24	19,05
857	Ferrolho n° 3	133	82	49	57	24	19,05
858	Ferrolho n° 4	150	106	49	82	24	19,05
923	Ferrolho n° 5	176	132	49	109	24	22
924	Ferrolho n° 6	197	155	49	133	24	22

Stanley duplo



Stanley duplo com porca

Codigo	Tamanho	A	B	C	D	E	F
1096	1" esferas	25,4	27	88	6	64	5/16
231	1" ¼ esferas	38	36	88	8	54	½
232	1 ½" esferas	31,5	31	88	7	60	5/16
521	Rolamento 608	22	26	88	7	63	5/16
233	Rolamento 6201	32	44	88	10	58	5/16
234	Rolamento 6202	35	44	88	11	55	½



Stanley duplo com chapa

Codigo	Tamanho	A	B	C	D	E	F	G
230	1" esferas	25,4	27	88	6	64	5/16	15x60
243	1" ¼ esferas	38	36	88	8	54	½	15x60
242	1 ½" esferas	31,5	31	88	7	60	5/16	15x60
437	Rolamento 608	22	26	88	7	63	5/16	15x60
561	Rolamento 6201	32	44	88	10	58	5/16	19x60
220	Rolamento 6202	35	44	88	11	55	½	19x60

Stanley quadruplo



Stanley quadruplo com porca

Codigo	Tamanho	A	B	C	D	E	F	G
238	1" esferas	25,4	27	88	6	64	5/16	80
239	1" ¼ esferas	38	36	92	8	54	½	90
240	1 ½" esferas	31,5	31	92	7	60	7,5	80
1055	Rolamento 608	22	26	88	7	63	7,5	80
706	Rolamento 6201	32	44	90	10	58	½	80
236	Rolamento 6202	35	44	90	11	55	½	90

Stanley quadruplo com chapa

Codigo	Tamanho	A	B	C	D	E	F	G
1054	1" esferas	25,4	27	88	6	64	5/16	80
227	1" ¼ esferas	38	36	92	8	54	½	90
395	1 ½" esferas	31,5	31	92	7	60	7,5	80
651	Rolamento 608	22	26	88	7	63	7,5	80
1332	Rolamento 6201	32	44	90	10	58	½	80
429	Rolamento 6202	35	44	90	11	55	½	90

Gonzo



Gonzo não passante

Codigo	Tamanho	A	B	C	D	E	F
260	3/8	10	6	30	20	10	20
261	1/2	12	8,5	34	22	12	22
263	5/8	15	10	37	25	12	25
262	3/4	19	12,7	45	30	15	30
264	7/8	22	12,7	50	35	15	35
265	1"	25	12,7	55	40	15	40
266	1" 1/4	32	18	70	45	25	45
441	1" 1/2	38	18	75	50	25	50

Gonzo não passante com furo



Codigo	Tamanho	A	B	C	D	E	F
535	3/8 (4cm)	10	6,3	30	20	10	20
674	1/2 (5,5cm)	12	8,5	40,5	22	12	27,5
199	5/8 (7cm)	15	10	35	25	15	35
343	3/4 (7cm)	19	12,7	35	30	15	35
344	7/8 (7cm)	22	12,7	35	35	15	35
670	1" (7cm)	25	12,7	40	40	15	40
225	1" 1/4 (9cm)	32	18	45	45	25	45
674	1" 1/2 (10cm)	38	18	102	50	25	50

Gonzo passante



Codigo	Tamanho	A	B	C	D	E	F
253	3/8	10	7,8	42	20	12	20
254	1/2	12	7,8	52	22	27	25
256	5/8	15	10	52	25	27	25
255	3/4	19	12,7	62	30	32	30
257	7/8	22	15,8	72	35	37	35
258	1"	25	17	82	40	42	40
259	1" 1/4	32	18	92	45	47	45
930	1" 1/2	38	18	102	50	52	50



Gonzo com aba

Codigo	Tamanho	A	B	C	D
267	3/8	21	43	11	35
268	1/2	21	44	12	44
270	5/8	25	51	15	56
269	3/4	31	61	18	63
271	7/8	34	70	23	69
272	1"	38	79	25	64

Kit para portão basculante

Modelo 01



KIT COMPLETO - MODELO 1

1. 02 ROLDANAS (OPCIONAL 3", 4" ou 5")
2. 02 PINOS GUIA 17 x 100m COM ROSCA C/ ROLAMENTO 6303
3. 02 BUCHA DE CANAL 1 x 15mm
4. 02 BUCHA LISA 1" x 40
5. 04 PINO 1" x 50mm
6. 01 CABO DE AÇO COM 3,8 METROS
7. 04 CLIPS
8. 06 PORCAS 1/2
9. 06 ARRUELAS
10. 02 BATENTES PEQUENOS
11. 02 BATENTES GRANDES

Kit modelo 01

Codigo	Referencia
245	kit p/ portão com roldana de 3"
246	kit p/ portão com roldana de 4 "
247	kit p/ portão com roldana de 5"

Modelo 02



KIT COMPLETO - MODELO 2

1. 02 ROLDANAS (OPCIONAL 3", 4" ou 5")
2. 02 PINOS GUIA 5/8 x 100 S/ ROSCA COM CAPA 48MM NYLON INJETADO
3. 02 BUCHA DE CANAL 1 x 11mm
4. 02 CANOS 7/8(21,3) x 65mm
5. 03 CANOS 1"1/4 x 40mm
6. 03 BARRA CHATA 1"1/4 x 3/16 x 80mm
7. 04 BARRA CHATA 1"1/4 x 3/16 x 200mm
8. 02 SUPORTE PARA BRAÇO DE ELEVAÇÃO
9. 02 PARAFUSOS 3/8 x 2"
10. 01 CABO DE AÇO COM 05 METROS
11. 04 CLIPS

Kit modelo 02

Codigo	Referencia
385	kit p/ portão com roldana de 3"
1042	kit p/ portão com roldana de 4 "
298	kit p/ portão com roldana de 5"

Caixas de Mola (Furo 1 1/4")



Diâmetro interno 180mm

40 mm	
Código	Comprimento
1497	2,5
1498	3,0
1499	3,5
1500	4,0
1501	4,5
1502	5,0
1503	5,5
1504	6,0

45mm	
Código	Comprimento
1505	2,5
595	3,0
399	3,5
400	4,0
401	4,5
364	5,0
1506	5,5
1507	6,0

50mm	
Código	Comprimento
1508	2,5
1113	3,0
568	3,5
634	4,0
720	4,5
721	5,0
1120	5,5
1509	6,0

Diâmetro interno 200mm

40mm	
Código	Comprimento
1510	2,5
1038	3,0
1039	3,5
1040	4,0
1056	4,5
1064	5,0
502	5,5
1511	6,0

45 mm	
Código	Comprimento
1114	2,5
1044	3,0
1045	3,5
1046	4,0
1047	4,5
1048	5,0
489	5,5
383	6,0

50 mm	
Código	Comprimento
1112	2,5
1057	3,0
1049	3,5
1058	4,0
1043	4,5
1059	5,0
381	5,5
382	6,0

Av. Paulo Piva, 260
Industrial
Presidente Olegário - MG

(34)3811-1245
contato@stsroldanas.com